

# Agilent Automation Integration Highlight

## LabCyte Echo Benchtop Integration

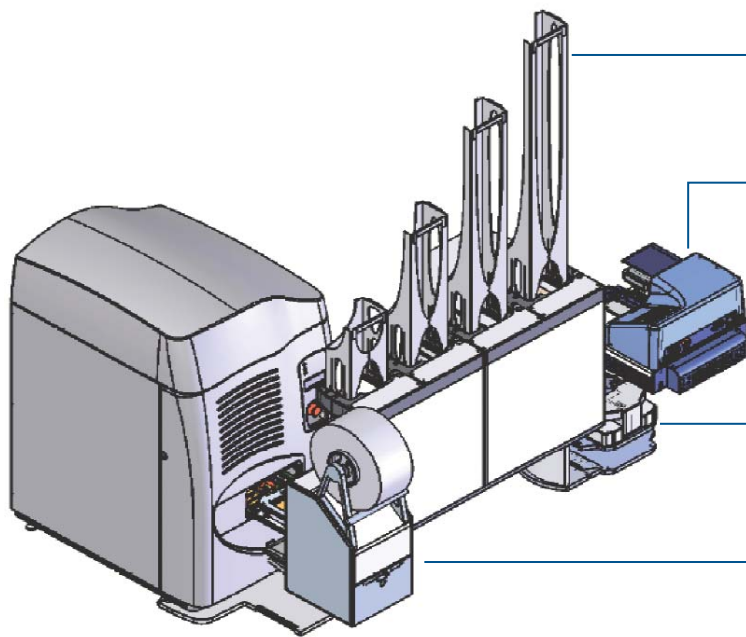

- **Agilent BenchCel w/4 Stacks**

Store and deliver source and destination microplates

- **Thermo Multidrop Combi**

Bulk dispensing of back-fill reagents

- **Agilent Microplate Centrifuge**

Spin-down source plate contents for acoustic dispensing

- **Agilent PlateLoc**

Seal plates for follow-on assays

Agilent BenchCel workstation with the LabCyte Echo Acoustic Dispenser and multiple microplate management instruments to create the most compact automated benchtop workstation for sample picking and dilution

### A Benchtop Solution:

The Agilent LabCyte Echo based Hit picking Workstation was developed to provide a cost effective, automated hit picking solution for compound inventory management.

With Agilent VWorks Automation Control software, the user has the ability to use LabCyte's built-in Cherry Picking and Dose Response applications or use VWorks scheduling tasks to create a customized workflow.

### Agilent Automation Benefits:

- **Plate Handling:** Most 1536-, 384-, and 96-well microplates, tube racks, and lids.
- **Flexibility:** Devices can be added or replaced to customize this solution.
- **Capability:** VWorks provides full control of the Echo system as well as LabCyte's Cherry Pick and Dose Response software and communications to LIMS or databases.
- **Reliability:** Create assay ready microplates unattended and error free.



**Agilent Technologies**

## Configuration Options

The Agilent BenchCel Workstations offer the flexibility of adding and reconfiguring options to meet your workflow requirements.

- **Labeling:** Replace the Agilent Centrifuge with an Agilent Microplate Labeler or add a second BenchCel and Microplate Labeler to apply barcode labels to your destination plates.
- **Capacity:** Replace the 4 stacker BenchCel with a 6 stacker BenchCel for additional capacity.
- **More:** Speak with one of our product specialists or application specialists to determine what configuration will work best for you.

## Additional Services

All BenchCel Workstations include installation and product familiarization along with options to purchase additional services to meet your specific needs. These options include:

- **Consulting:** Work with a team of experts to determine the best solution for your laboratory.
- **Application Development:** Let our application specialists develop and test system protocols for your applications.
- **More:** Speak with one of our product specialists regarding any additional support you require to ensure our solution meets all of your needs.

[www.agilent.com/lifesciences/automation](http://www.agilent.com/lifesciences/automation)

Agilent Technologies shall not be liable for errors contained herein or for incidental or consequential damages in connection with the furnishing, performance, or use of this material.

Information, descriptions, and specifications in this publication are subject to change without notice.

© Agilent Technologies, Inc. 2009  
Published in the USA  
July 30, 2009  
5990-4332EN



**Agilent Technologies**